



## **ALTERNATOR PRO28L G/4**

*three-phase brushless synchronous alternator with AVR - 4 poles*

Technical Data Sheet

## PRO28L G/4

### COMMON DATA

Rated Power at 50Hz	kVA	400	
Rated Power at 60Hz	kVA	480	
Rated Power Factor		0.8	
Nominal Temperature	°C	40	
Control System		self excited	
Execution		brushless	
Regulation Type		AVR	
Insulation Class		H	
Protection		IP23	
Maximum Overspeed	rpm	2250	
Overload		110% of rated power for one hour in a cycle of 6 hours	
Air Flow Requirement	m <sup>3</sup> /min	44.4 at 50Hz	49.6 at 60Hz
R.F.I. Suppression		Standard EN55011	

### REGULATION DATA

AVR	HVR30	\
Sensing	three-phase	\
Voltage Regulation	±1%	
Sustained Short Circuit	> 300% of rated current	

### WINDING DATA

Stator Winding	Double layer with auxiliary winding	
Rotor Winding	with damping cage	
Winding Pitch	2/3	
Number of Leads of Stator	6	
Stator Winding Resistance	0.0061 at 20°C	
Rotor Winding Resistance	3.15 at 20°C	
Exciter Stator Resistance	15 at 20°C	
Exciter Rotor Resistance	0.25 at 20°C	
THD at full load	<3%	
THD at no load	<3%	
Excitation at no load	A <sub>dc</sub>	0.6
Excitation at full load	A <sub>dc</sub>	2.2

### STANDARD

References	EN60034-1 ISO8528-3 EN55011
------------	-----------------------------

## PRO28L G/4

### ELECTRICAL DATA

Frequency		50Hz - 1500rpm				60Hz - 1800rpm			
Voltage Series Star	V	<b>380/220</b>	<b>400/230</b>	<b>415/240</b>	<b>440/254</b>	<b>415/240</b>	<b>440/254</b>	<b>460/266</b>	<b>480/277</b>
Rated Power in Class H (125°C/40°C)	kVA	400	400	400	380	430	460	480	480
	kW	320	320	320	304	344	368	384	384
Rated Power in Class F (105°C/40°C)	kVA	360	360	360	340	386	415	430	430
	kW	288	288	288	272	308.8	332	344	344
Rated Power Standby (150°C/40°C)	kVA	410	410	410	390	435	470	490	490
	kW	328	328	328	312	348	376	392	392
Rated Power Standby (163°C/27°C)	kVA	420	420	420	400	445	480	500	500
	kW	336	336	336	320	356	384	400	400

### EFFICIENCY IN CL. H

4/4		93.8%						94.2%
3/4		94.0%						94.4%
2/4		93.1%						93.5%
1/4		90.0%						90.1%

### REACTANCES AND TIME CONSTANTS

pcc		0.41							
X <sub>d</sub> - dir. axis synchronous		366%	330%	307%	259%	395%	376%	359%	330%
X' <sub>d</sub> - dir. axis transient		19.9%	18.0%	16.7%	14.1%	21.6%	20.5%	19.6%	18.0%
X'' <sub>d</sub> - dir. axis subtransient		10.0%	9.0%	8.4%	7.1%	10.8%	10.3%	9.8%	9.0%
X <sub>q</sub> - quad. axis reactance		233%	210%	195%	165%	252%	240%	229%	210%
T' <sub>do</sub> - O.C. field time constant		1910ms							
T' <sub>d</sub> - Transient time constant		116ms							
T'' <sub>d</sub> - Sub-transient time constant		14ms							

### MECHANICAL DATA

Bearing non drive end				6314-2RS-C3
Bearing drive end (B3/B14 form)				6316-2RS-C3
Weight of generator	in B2	kg		1034
	in B3/B14	kg		1045
	in B3/B9	kg		\

# PRO28L G/4

## MOMENT OF INERZIA

B3/B9	kg·m <sup>2</sup>	\
SAE 7½	kg·m <sup>2</sup>	\
SAE 8	kg·m <sup>2</sup>	\
SAE 10	kg·m <sup>2</sup>	\
SAE 11½	kg·m <sup>2</sup>	4.916
SAE 14	kg·m <sup>2</sup>	5.032
SAE 18	kg·m <sup>2</sup>	\
B3/B14	kg·m <sup>2</sup>	4.737

## POWER VARIATION ACCORDING TO TEMPERATURE AND ALTITUDE

Altitude	Ambient temperature				
	25°C	40°C	45°C	50°C	55°C
< 1000m	1.09	1	0.96	0.93	0.91
1000m - 1500m	1.01	0.96	0.92	0.89	0.87
1500m - 2000m	0.96	0.91	0.87	0.84	0.83
2000m - 3000m	0.9	0.85	0.81	0.78	0.76

## WIRING DIAGRAM

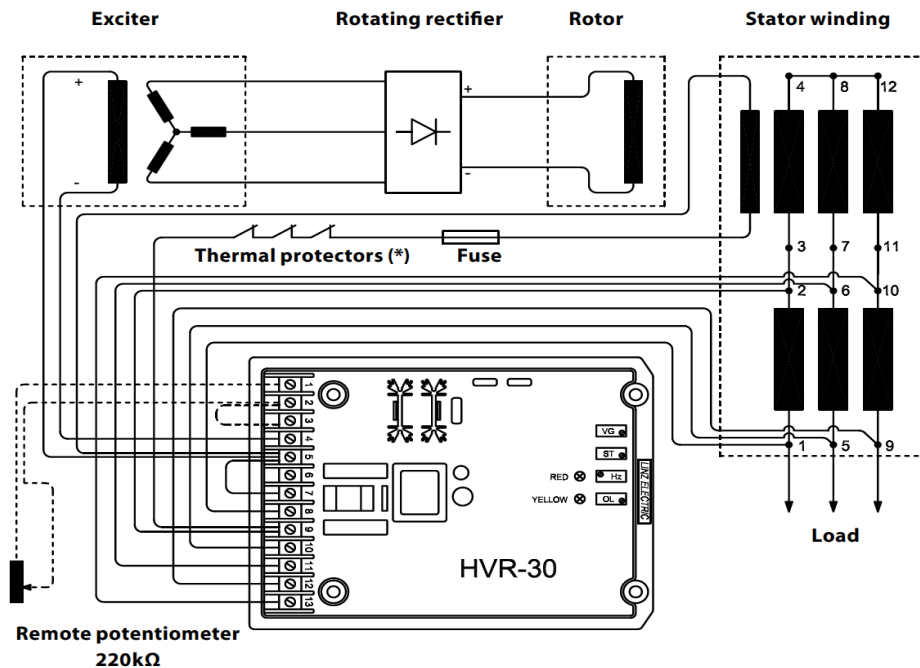

**PRO28L G/4**

**TRANSIENT VOLTAGE VARIATION 50Hz**

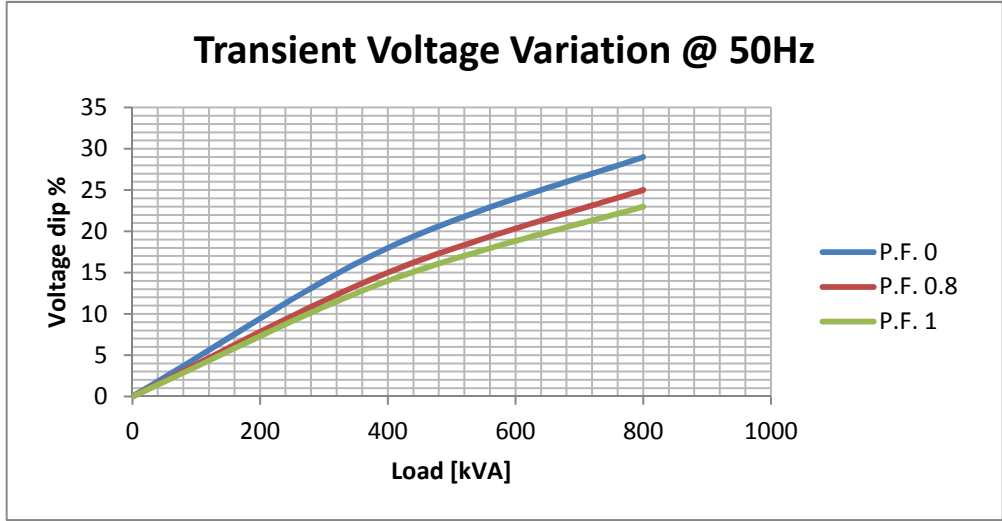

**TRANSIENT VOLTAGE VARIATION 60Hz**

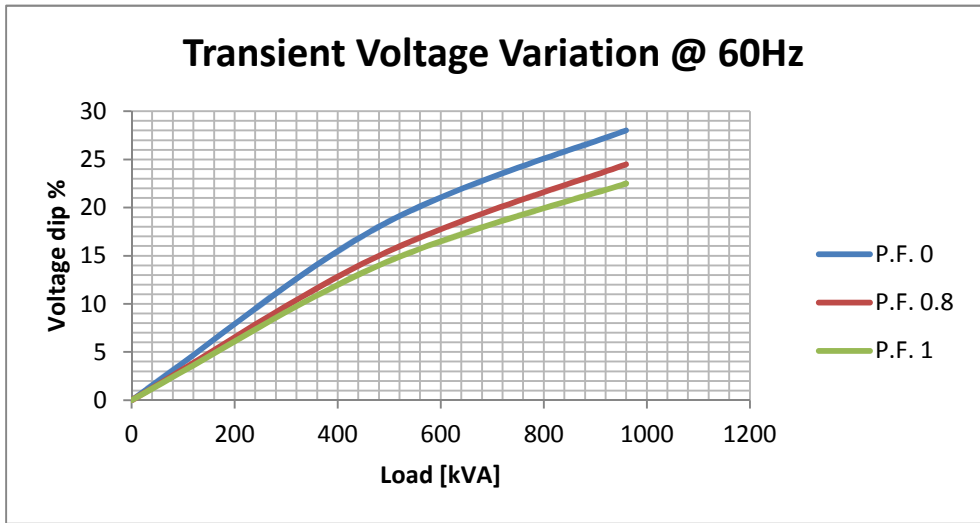

**PRO28L G/4**

**EFFICIENCY 50Hz**

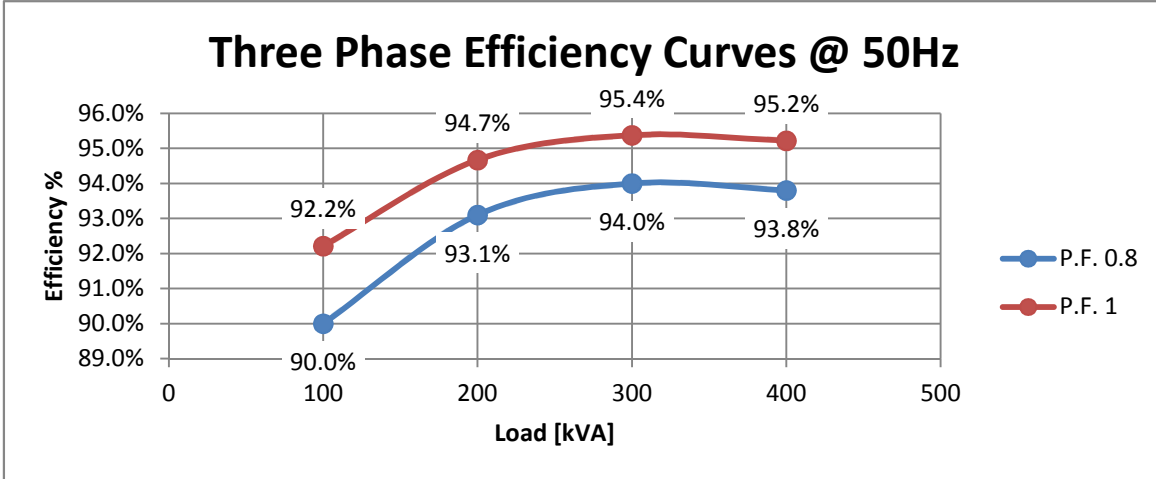

**EFFICIENCY 60Hz**

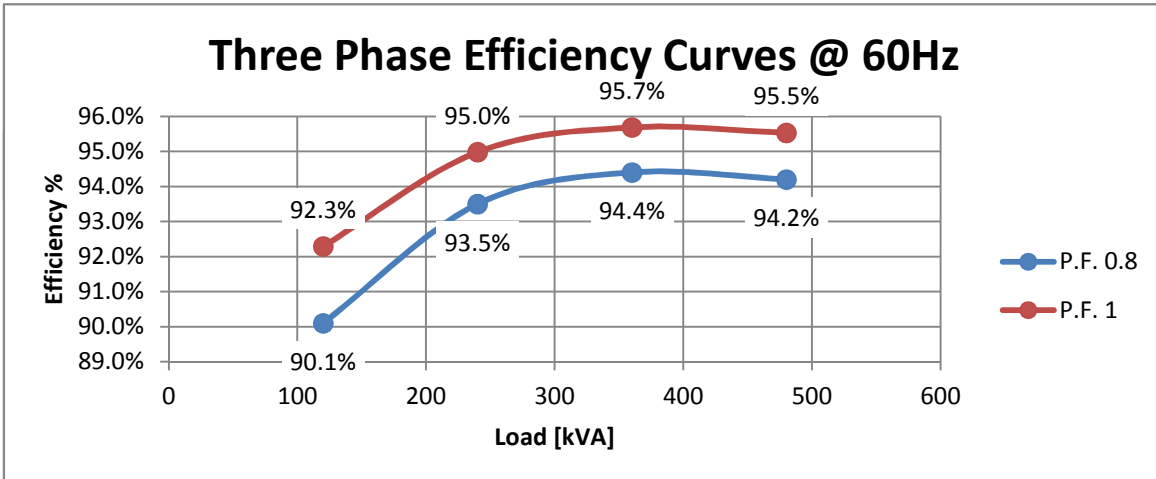

# PRO28L G/4

FORMA - FORM B3/B14

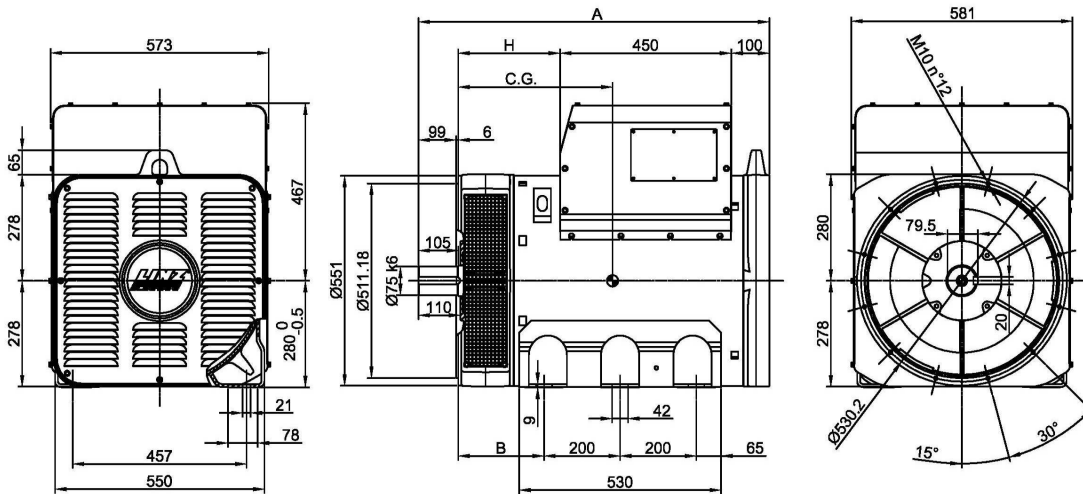

FORMA - FORM SAE

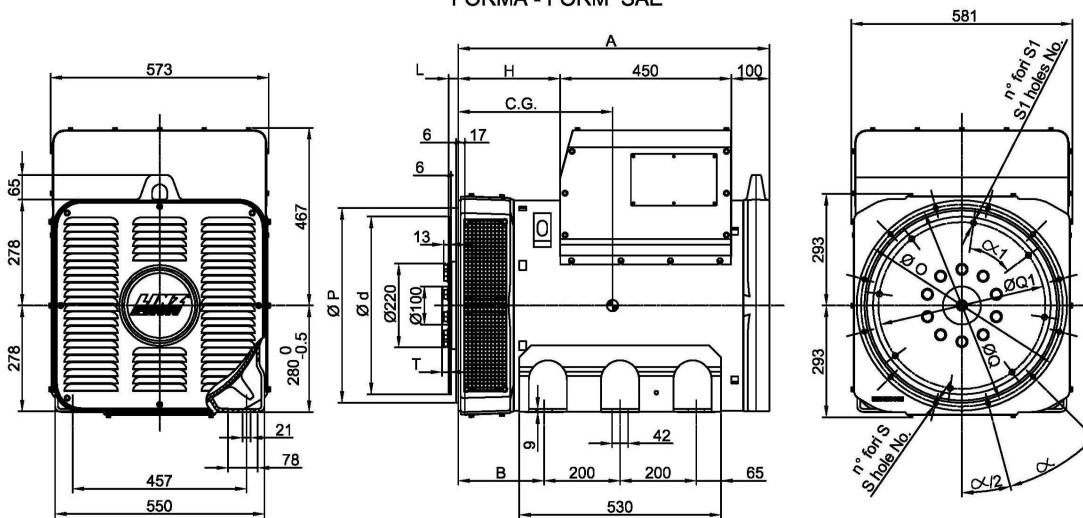

FORMA - FORM		A	B	H	TIPO - TYPE	C.G.
B3/B14	PRO 28S	922	225	267	PRO28S A/4	376
	PRO 28M	1072		417	PRO28S B/4	380
	PRO 28L	1137	325	482	PRO28S C/4	394
SAE	PRO 28S	817	225	267	PRO28S D/4	406
	PRO 28M	967		417	PRO28M E/4	452
	PRO 28L	1032	325	482	PRO28M F/4	480
					PRO28L G/4	513

SAE N.	FLANGIE - FLANGES - BRIDAS					
	Ø O	Ø P	Ø Q	n. fori holes No.	S	α
3	451	409.6	428.6	12	12	30°
2	490	447.68	466.7			
1	552	511.18	530.2			

SAE N.	GIUNTI A DISCO - COUPLING DISCS - JUNTAS A DISCOS						
	L	Ø d	Ø Q1	n. fori holes No.	S1	α1	T
11 1/2	39.6	352.42	333.37	8	10.5	45°	0
14	25.4	466.72	438.15	8	14	45°	17.3