



ALTERNATOR PRO22S B/4

three-phase brushless synchronous alternator with AVR - 4 poles

Technical Data Sheet

PRO22S B/4

COMMON DATA

Rated Power at 50Hz	kVA	75	
Rated Power at 60Hz	kVA	90	
Rated Power Factor		0.8	
Nominal Temperature	°C	40	
Control System		self excited	
Execution		brushless	
Regulation Type		AVR	
Insulation Class		H	
Protection		IP23	
Maximum Overspeed	rpm	2250	
Overload		110% of rated power for one hour in a cycle of 6 hours	
Air Flow Requirement	m ³ /min	18 at 50Hz	21.6 at 60Hz
R.F.I. Suppression		Standard EN55011	

REGULATION DATA

AVR	HVR11	HVR30
Sensing	single-phase	three-phase
Voltage Regulation	±1%	±1%
Sustained Short Circuit	> 300% of rated current	

WINDING DATA

Stator Winding	Double layer with auxiliary winding	
Rotor Winding	with damping cage	
Winding Pitch	2/3	
Number of Leads of Stator	12	
Stator Winding Resistance	0.03 at 20°C	
Rotor Winding Resistance	2.6 at 20°C	
Exciter Stator Resistance	14.3 at 20°C	
Exciter Rotor Resistance	0.47 at 20°C	
THD at full load	<3%	
THD at no load	<2,5%	
Excitation at no load	A _{dc}	0.9
Excitation at full load	A _{dc}	2.5

STANDARD

References	EN60034-1 ISO8528-3 EN55011
------------	-----------------------------

PRO22S B/4

ELECTRICAL DATA

Frequency		50Hz - 1500rpm				60Hz - 1800rpm			
Voltage Series Star	V	380/220	400/230	415/240	440/254	415/240	440/254	460/266	480/277
Rated Power in Class H (125°C/40°C)	kVA	75	75	70	65	81	86	90	90
	kW	60	60	56	52	64.8	68.8	72	72
Rated Power in Class F (105°C/40°C)	kVA	69	69	65	62	75	80	83	83
	kW	55.2	55.2	52	49.6	60	64	66.4	66.4
Rated Power Standby (150°C/40°C)	kVA	80	80	75	70	86	90	95	95
	kW	64	64	60	56	68.8	72	76	76
Rated Power Standby (163°C/27°C)	kVA	85	85	80	75	90	93	98	98
	kW	68	68	64	60	72	74.4	78.4	78.4

EFFICIENCY IN CL. H

4/4		90.3%						90.4%
3/4		90.5%						90.7%
2/4		89.5%						90.6%
1/4		86.2%						87.3%

REACTANCES AND TIME CONSTANTS

pcc		0.53						
X _d - dir. axis synchronous		334%	301%	261%	216%	362%	342%	301%
X' _d - dir. axis transient		21.1%	19.0%	16.5%	13.6%	22.9%	21.6%	19.0%
X'' _d - dir. axis subtransient		10.5%	9.5%	8.2%	6.8%	11.4%	10.8%	9.5%
X _q - quad. axis reactance		216%	195%	169%	140%	235%	222%	195%
T' _{do} - O.C. field time constant		245ms						
T' _d - Transient time constant		21ms						
T'' _d - Sub-transient time constant		12ms						

MECHANICAL DATA

Bearing non drive end				6309-2RS-C3
Bearing drive end (B3/B14 form)				6314-2RS-C3
Weight of generator	in B2	kg		295
	in B3/B14	kg		315
	in B3/B9	kg		\

PRO22S B/4

MOMENT OF INERZIA

B3/B9	kg·m ²	\
SAE 7½	kg·m ²	\
SAE 8	kg·m ²	\
SAE 10	kg·m ²	\
SAE 11½	kg·m ²	0.853
SAE 14	kg·m ²	1.001
SAE 18	kg·m ²	\
B3/B14	kg·m ²	0.775

POWER VARIATION ACCORDING TO TEMPERATURE AND ALTITUDE

Altitude	Ambient temperature				
	25°C	40°C	45°C	50°C	55°C
< 1000m	1.09	1	0.96	0.93	0.91
1000m - 1500m	1.01	0.96	0.92	0.89	0.87
1500m - 2000m	0.96	0.91	0.87	0.84	0.83
2000m - 3000m	0.9	0.85	0.81	0.78	0.76

WIRING DIAGRAM

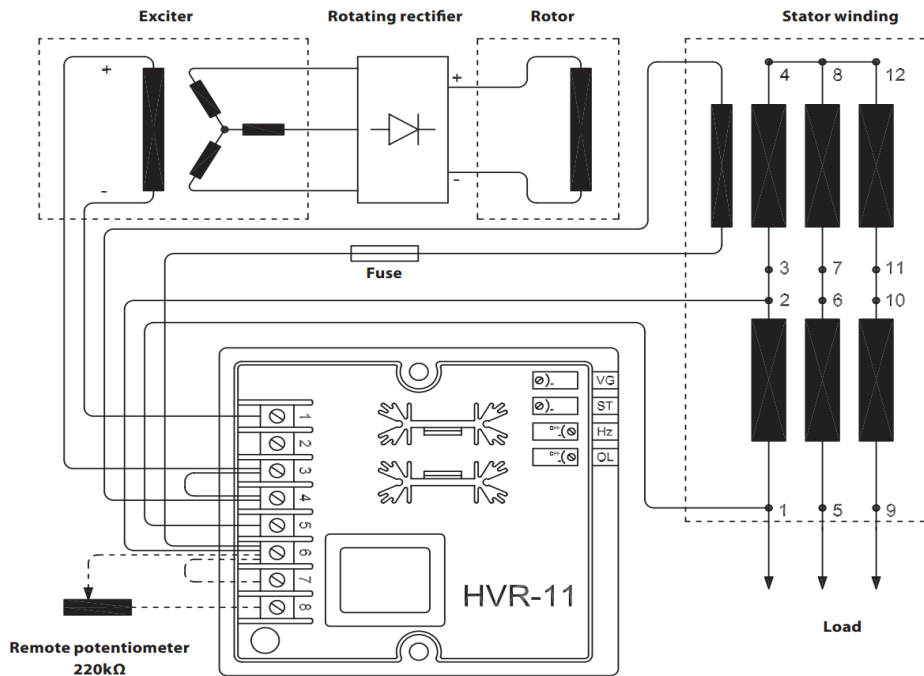

PRO22S B/4

TRANSIENT VOLTAGE VARIATION 50Hz

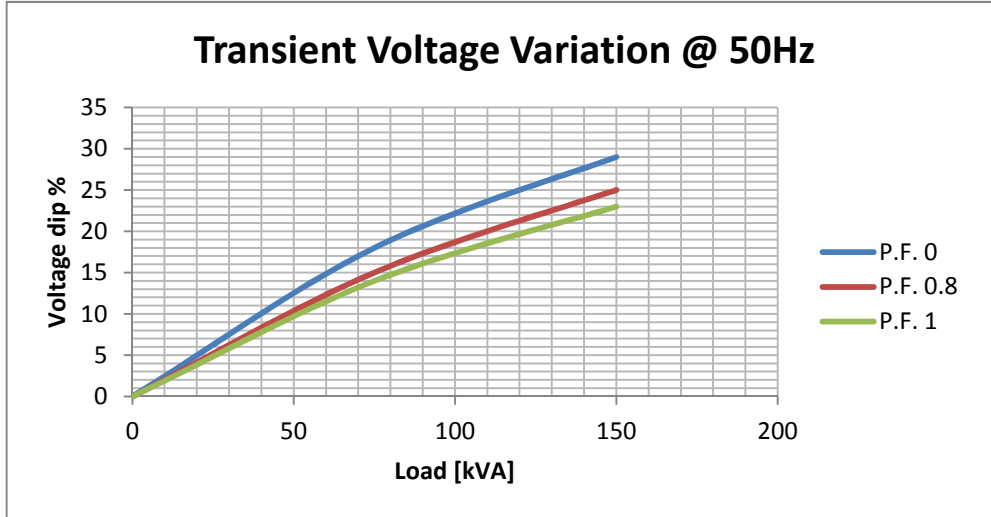

TRANSIENT VOLTAGE VARIATION 60Hz

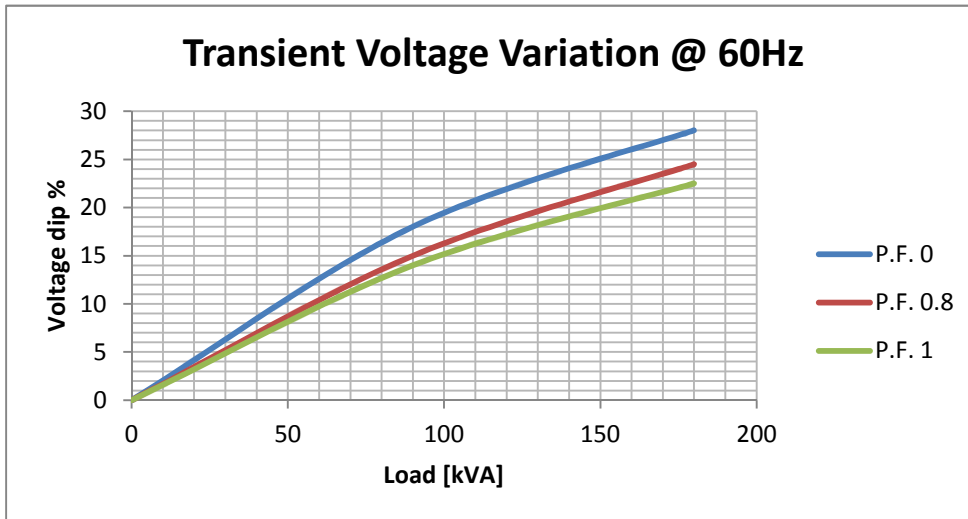

PRO22S B/4

EFFICIENCY 50Hz

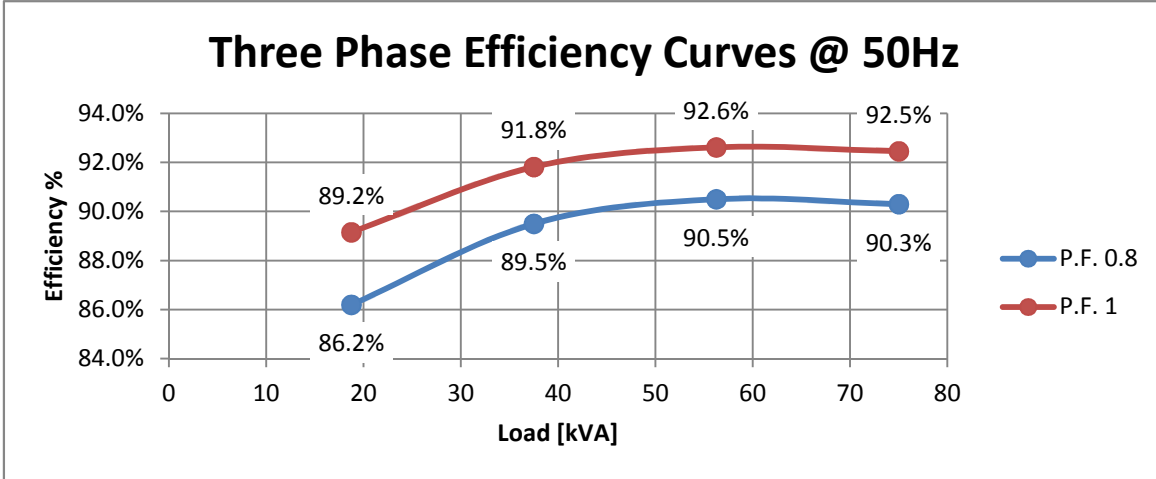

EFFICIENCY 60Hz

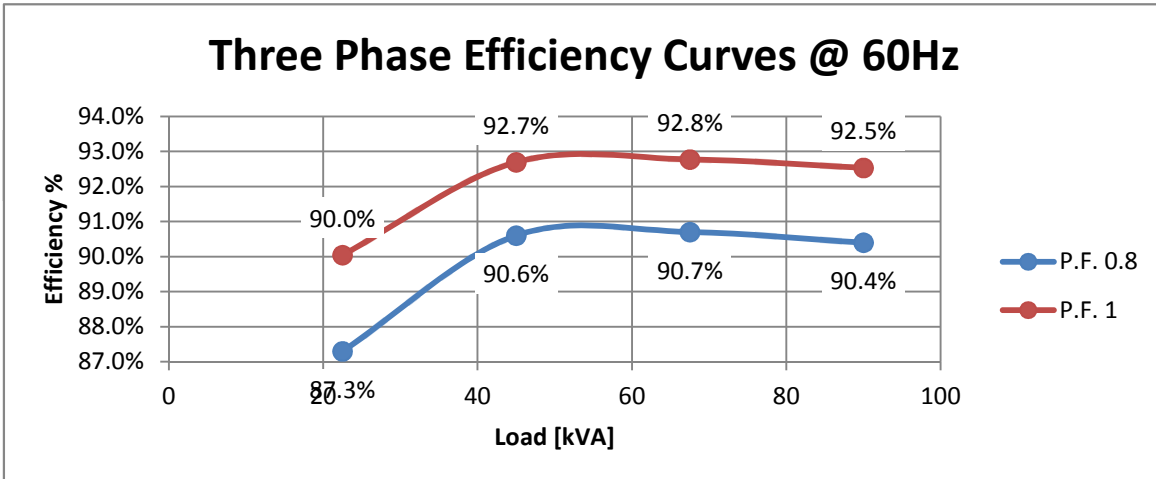

PRO22S B/4

FORMA - FORM B3/B14

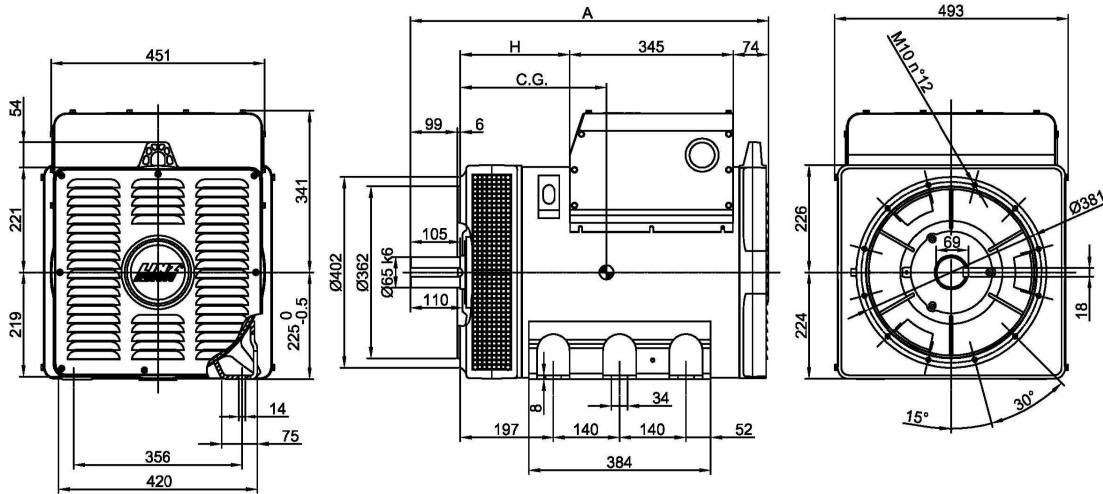

FORMA - FORM SAE

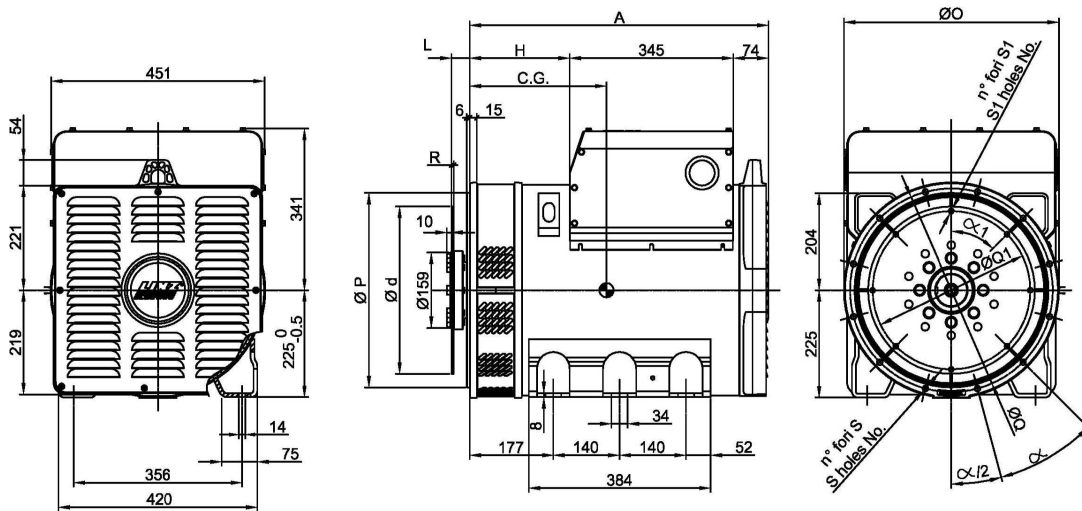

FORMA - FORM		A	H
B3/B14	PRO 22S	756	232
	PRO 22M	886	362
SAE	PRO 22S	631	212
	PRO 22M	761	342

TIPO - TYPE	C.G.
PRO22S A/4 B3/B14	284
PRO22S B/4 B3/B14	293
PRO22S C/4 B3/B14	299
PRO22S D/4 B3/B14	313
PRO22M E/4 B3/B14	359
PRO22M F/4 B3/B14	377

TIPO - TYPE	C.G.
PRO22S A/4 SAE	270
PRO22S B/4 SAE	279
PRO22S C/4 SAE	285
PRO22S D/4 SAE	298
PRO22M E/4 SAE	344
PRO22M F/4 SAE	362

SAE N.	FLANGIE - FLANGES - BRIDAS					
	Ø O	Ø P	Ø Q	n. fori holes No.	S	α
3	454	409.6	428.6	12	12	30°
2	492	447.68	466.7			
1	552	511.18	530.2			

SAE N.	GIUNTI A DISCO - COUPLING DISCS - JUNTAS A DISCOS						
	L	Ø d	Ø Q1	n. fori holes No.	S1	α1	R
11 1/2	39.6	352.42	333.37	8	10.5	45°	6
14	25.4	466.72	438.15	8	14	45°	